

deta *INTERNATIONAL*

#40 DISK TYPE TOOL CHANGER SYSTEM

USER MANUAL

This manual is applicable to model:

MR4AL

BT40/CAT40/DIN40/HSK50A/HSK63A

Revised date:2015/04/24

# Contents

# Page

1、Tool Changer System Mechanical Specification & Drawing .....	02
2、Power Supply Specification for Electrical Control .....	05
3、Electrical Control .....	06
4、Electrical Control Protection Programming .....	07
5、Installation Procedure .....	08
6、Original Setting.....	10
7、Trouble Shooting.....	11
8、Maintenance .....	16

# 1、Tool Changer System Mechanical Specification & Drawings :

## 1-1. Specification:

Item	Model	MR4AL
Tool Capacity		24T
Maximum Tool Diameter		75mm
Max. Tool Length		300mm
Max. Tool Weight		7Kgf
Total Tool Weight		120 Kgf
CAM BOX Speed (CAM BOX Only)		1.5 sec. (60Hz)
Magazine Speed		0.6 sec. / tool (60Hz)
Tool Selection		Two Way Random Selection

## 1-2. Maximum Tool Rotational Inertia Diagram:

**Drawing:**

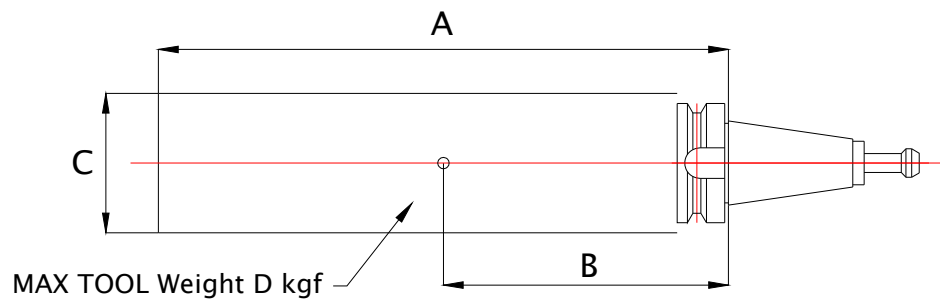

A	tool length
B	tool median point(A/2)
C	tool diameter
D	tool weight
MOMENT = $D * B (\leq 10.29 \text{ N-m})$	

### **1-3. Drawings:**

Assembly drawing and part list for disk type tool magazine, CAM BOX and tool changing arm as per attached drawings and list.

ITEM NO	PART NO.	TITLE-C	TITLE-E	QTY.	MATERIAL
1	MR4AK0001J02	本體	Body	1	FC30
2	MR4AK0002A00	刀盤組	Tool Disk Module	1	
3	MR4AK0004A00	壓缸固定鉸組	Cylinder Mounting Plate Moudule	1	
4	MR4AK0025A04	倒刀定位座	Pocket Positioning Seat	1	Nylon+40纖
5	MR4AK0005F01-T-10	倒刀壓缸	Pneumatic Cylinder	1	市購品
6	MR4AK0010A06	前蓋支撐桿	Support Rod	4	SS41
7	MR4AK0018B01	倒刀蓋板	Cover Plate	1	SS41(2t)
8	MR4AK0006A06	倒刀塊	Tool Tilt Block	1	S45C
9	MR4AK0026C01	Sensor感應板	Sensor Block	1	SS41(3t)
10	R4KKV0009A01	Sensor固定板	Sensor Lock Block	1	SS41
11	MR4AK0013A02	刀套固定桿	Shaft	24	S45C
12	MR4AK0014W02-31	渦輪減速機1:40+馬達1/2HP	Woem Gear +Motor	1	市購品
14	MR4AK00003A02	驅動軸	Tool Disk Driver	1	S45C
15	EB000000CF6G	曲線滾輪	Roller	2	CF6B
16	MR4AK0036A01	定位感應片	Positioning Sensor Block	1	SS41
17	MR4AK0007A05	壓缸前蓋	Front Of Cover	1	ABS
18	MR4AK0034A03	刀庫前外罩	MAG Front Cover	1	FRP
19	MR4A-0019A01	承靠塊	Positioning Key	2	S45C
20	P42K-0650115-01	BT刀套	Pocket	24	
21	SR4000000003	近接開關	Proximity Sensor	5	市購品
22	EB00PS181109	電控盒PS-1811-09	CE BOX	1	
24	MR4AK0035A02	CAMBOX外罩	COMBOX COVER	1	SS41
25	WA0000000008	墊片M8	Washer	24	市購品
26	M8xP1.25x30L	內六角承窩頭螺絲	Hexagon Socket Heard Screw	4	
27	WA0000000008	平墊圈M8	Finshed Circular Plain Washer	4	
28	WA0000000006	平墊圈M6	Finshed Circular Plain Washer	15	
29	M8xP1.25x20L	內六角承窩頭螺絲	Hexagon Socket Heard Screw	24	
30	M6xP1.0x10L	內六角承窩頭螺絲	Hexagon Socket Heard Screw	11	
31	M6xP1.0x12L	圓頭內六角承窩頭螺絲	Hexagon Socket Button Heard Screw	2	
32	WA0000000010	平墊圈M10	Spring Lock Washer	4	
33	M10xP1.5x30L	內六角承窩頭螺絲	Hexagon Socket Heard Screw	4	
34	WA0000000006	平墊圈M6	Spring Lock Washer	4	
35	M6xP1.0 x12L	內六角承窩頭螺絲	Hexagon Socket Heard Screw	4	
36	M8xP1.25x12L	內六角承窩頭螺絲	Hexagon Socket Heard Screw	5	
37	M6xP1.0x10L	圓頭內六角承窩頭螺絲	Hexagon Socket Button Heard Screw	2	
38	9-02M12	六角螺帽M12	Nut(M12)	4	
39	BT0000000020	吊環螺栓	Eye Bolt	1	
40	M6xP1.0x10L	圓頭內六角承窩頭螺絲	Hexagon Socket Button Heard Screw	4	

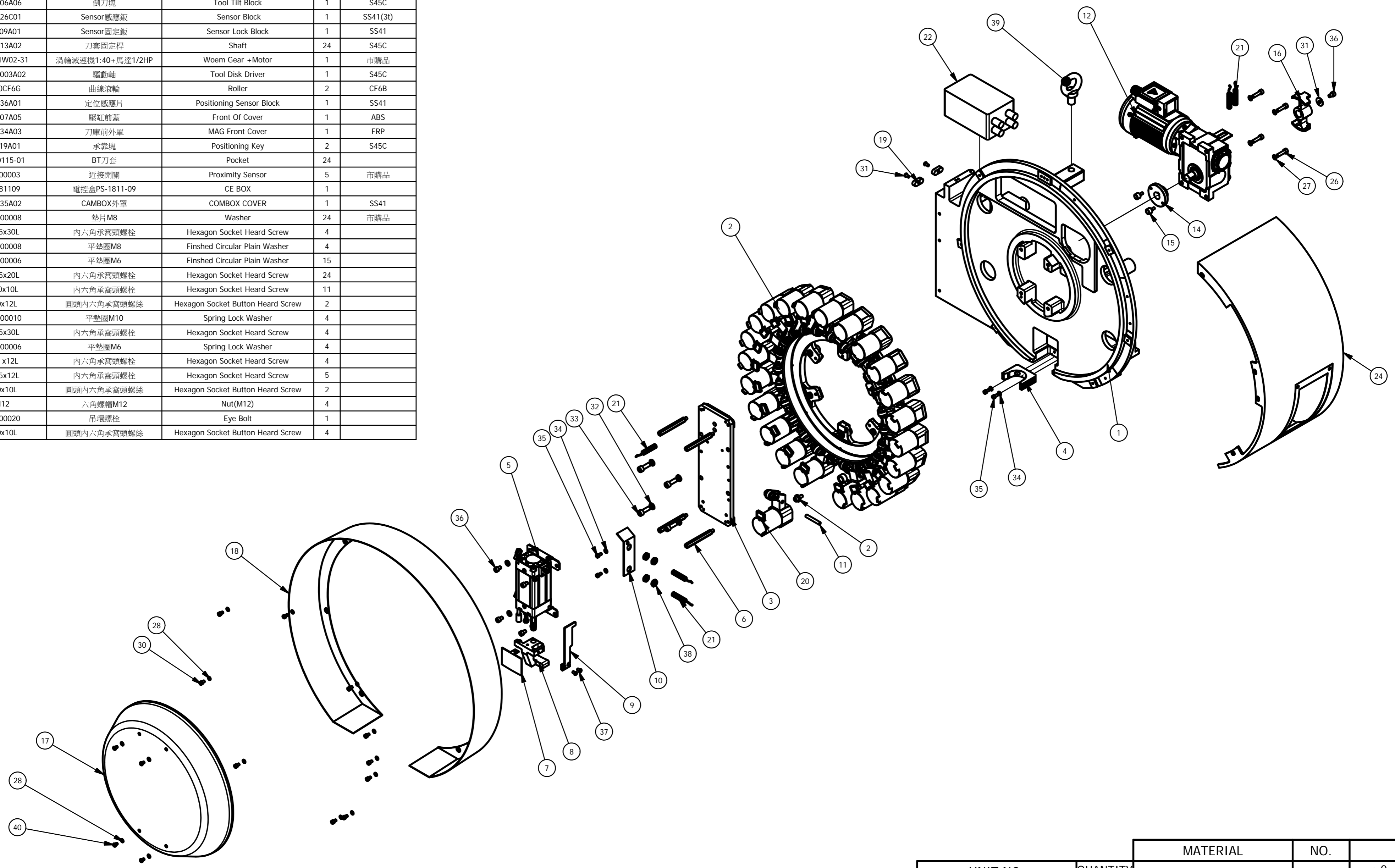

UNIT NO.	QUANTITY	MATERIAL	NO.	
			圖框更新版本	>0 ±0.1
			2009/12/29	>6 ±0.2
				>30 ±0.3
				>120 ±0.5
				>350 ±0.8
				>1000±1.2

**deta INTERNATIONAL**  
 TEL:886-4-25617722 FAX:886-4-25617177  
 DRAWING DESING  
 CHECK APPROVE  
 NAME ANGEL2014/5/26

PART NO. MR4AL0001A01  
 SCALE

TITLE  
 NMR4AE(#40X24T)  
 NMR4AE(#40X24T)

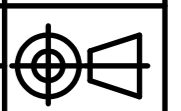

零件表						
項目	零件號碼	TITLE-C	TITLE-E	數量	材質	描述
1	MR4AK0002B02	刀盤	Tool Disk	1	A356-T6	
2	MR4AK0058A01	鎖固片		1	SS41	
3	P42K-0800115-01	刀套	Pocket	24		選配
3	MR4AK0013A02	刀套固定桿	Shaft	24	S45C	
4	NT0000000010	六角螺帽M10	Hexagon Nut	6		市購品
5	BE00000CF10G	軸承CF10G	Roller	6		市購品
6	MR4AK0011A02	耐磨片	Wear resistant Strip	6		
7	FM0000006010	皿頭螺絲M6x10L	Socket Countersunk Head Screw	6		市購品
8	CAP000008020	內六角承窩螺絲 8*20L(訂製品)φ25	Hexagon Socket Head Screw	24		市購品

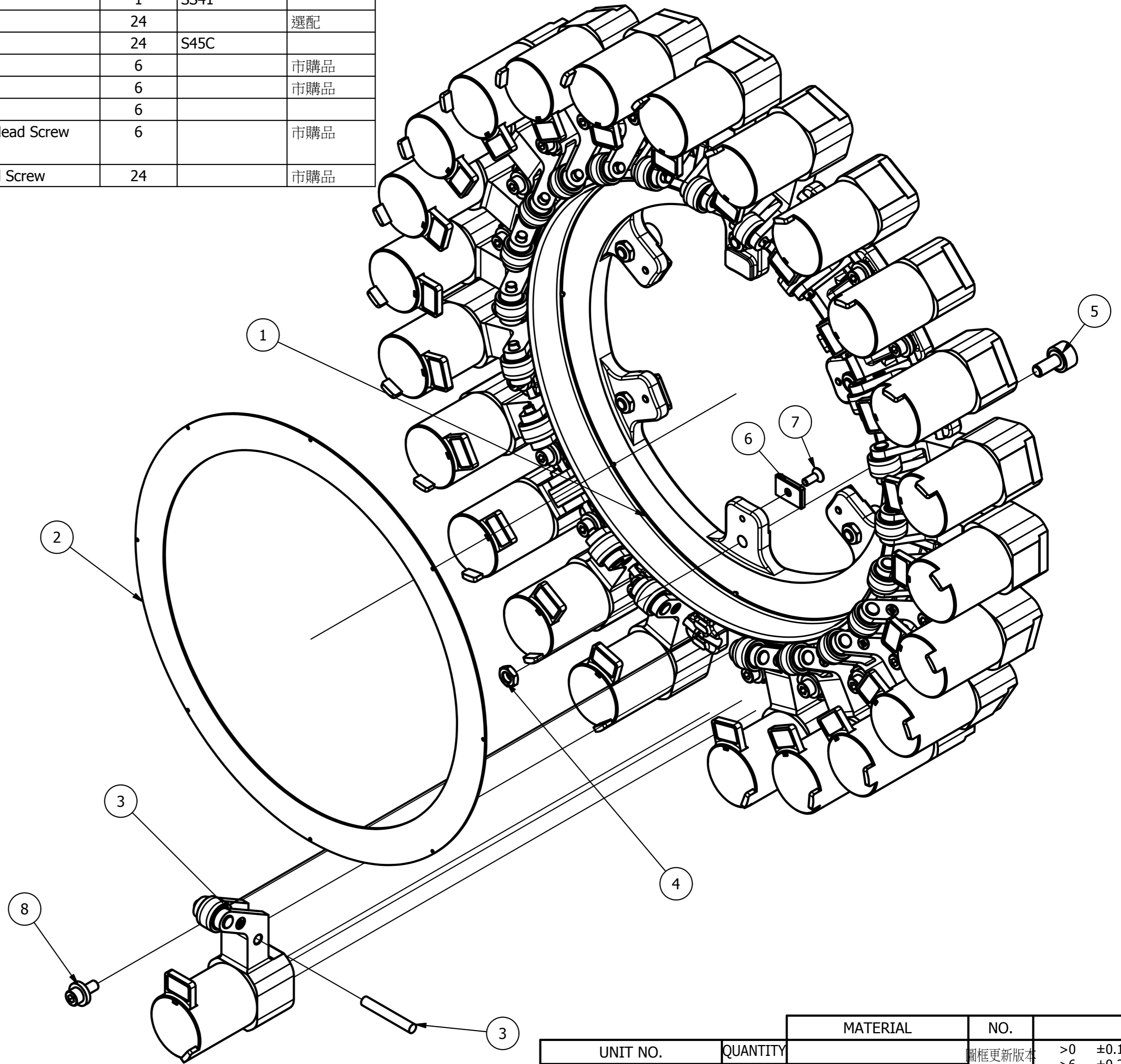

deta INTERNATIONAL  
TEL:886-4-25617722 FAX:886-4-25617177

NAME	wayne2014/3/4	DRAWING DESING	CHECK APPROVE
------	---------------	----------------	---------------

UNIT NO.	QUANTITY	MATERIAL	NO.	
PART NO.	SCALE	TITLE	圖框更新版本	>0 ±0.1
MR4AK0002A00		刀盤組	2009/12/29	>6 ±0.2
		Tool Disk Module		>30 ±0.3
				>120 ±0.5
				>350 ±0.8
				>1000±1.2

ITEM NO	PART NO.	QTY.	MATERIAL	TITLE-C	TITLE-E	NOTE
1	MR4AK0004A10	1	SS41	壓缸固定板	Cylinder Mounting Plate	
2	MR4AK0012A07	2	UP	耐磨片	Wear Resistant Strip(II)	
3	BS 4168 - M6 x 16	4		內六角皿頭螺柱	Socket Countersunk Head Screw	

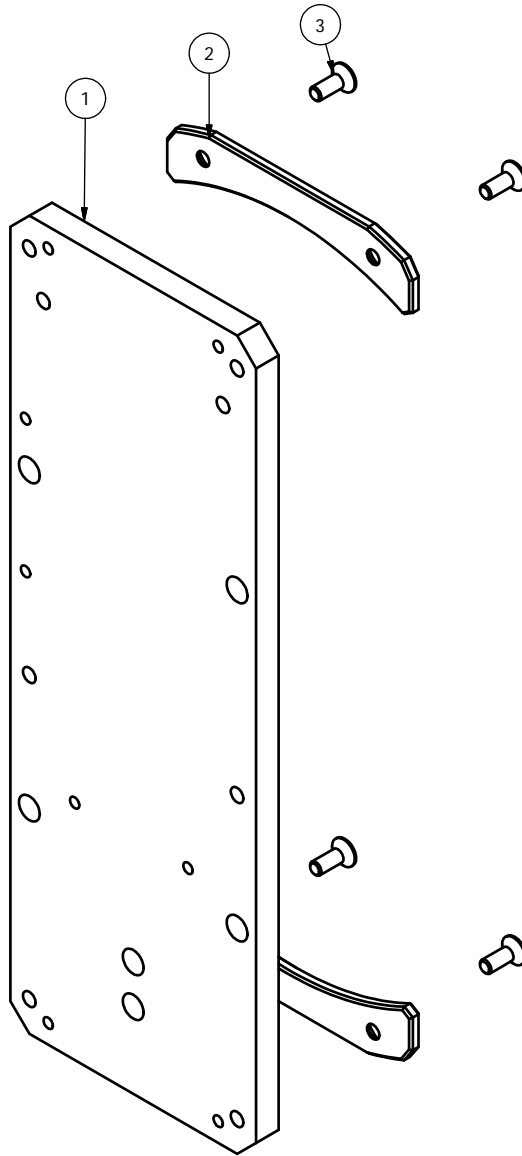

UNIT NO.	QUANTITY	MATERIAL	NO.	
			圖框更新版本	>0 ±0.1
			2009/12/29	>6 ±0.2
				>30 ±0.3
				>120 ±0.5
				>350 ±0.8
				>1000 ±1.2

<b>deta INTERNATIONAL</b>		DRAWING DESING	CHECK APPROVE
TEL:886-4-25617722 FAX:886-4-25617177	NAME	wayne2014/3/4	

PART NO.	SCALE	TITLE	
MR4AK0004A00		壓缸固定板組	
		Cylinder Mounting Plate Module	



ITME NO.	PART NO.	TITLE-C	TITLE-E	QTY.	MATERIAL
1	A40C-2651AC01	刀臂本體	Main Body	1	AL7075
2	A40C-0002A04	扣刀爪	Gripper	2	C50C
3	A40C-0028C04	頂刀爪	Finger	2	S50C
4	A40C-0007A02	頂刀爪彈簧	Finger Spring	2	SWPB
5	A40C-0004A03	定位銷	Key	2	S45C
6	00A40C-0020C	銅套組	COPPER COVER	2	
7	A40C-0005A07	安全頂銷	Safety Cover	2	S45C
8	A40C-0013F04	頂刀爪限位板	Position Limited Plate	2	SMF5030
9	A40C-0008A02	安全頂銷彈簧	Safety Spring Pin	2	SWPB
10	A40C-0006C03	彈簧蓋板	Spring Cover	2	SS41
11	A40C-0009A03	迫緊環蓋	Cox Cover	1	SCM4
12	CX0000d40D45	迫緊環	Taper Snap Ring	2	
13	OTTW00SER08V	刮刷環 II	Seal II	2	
14	M5xP0.8x16L	內六角承窩頭螺栓	Hxagon Socket Heard Screw	4	
15	M5xP0.8x30L	內六角承窩頭螺栓	Hxagon Socket Heard Screw	6	
16	M6	彈簧墊圈	Spring Lock Washer	8	
17	M6xP1.0x16L	內六角承窩頭螺栓	Hxagon Socket Heard Screw	8	
18	M8	彈簧墊圈	Spring Lock Washer	8	
19	M8xP1.25x16L	內六角承窩頭螺栓	Hxagon Socket Heard Screw	8	
20	8x25L	彈簧銷	Spring Pin	4	
21	M5xP0.8x10L	內六角皿頭螺栓	Socket Countersunk Heard Screw	2	
22	M5	彈簧墊圈	Spring Lock Washer	4	
23	M5	彈簧墊圈	Spring Lock Washer	6	

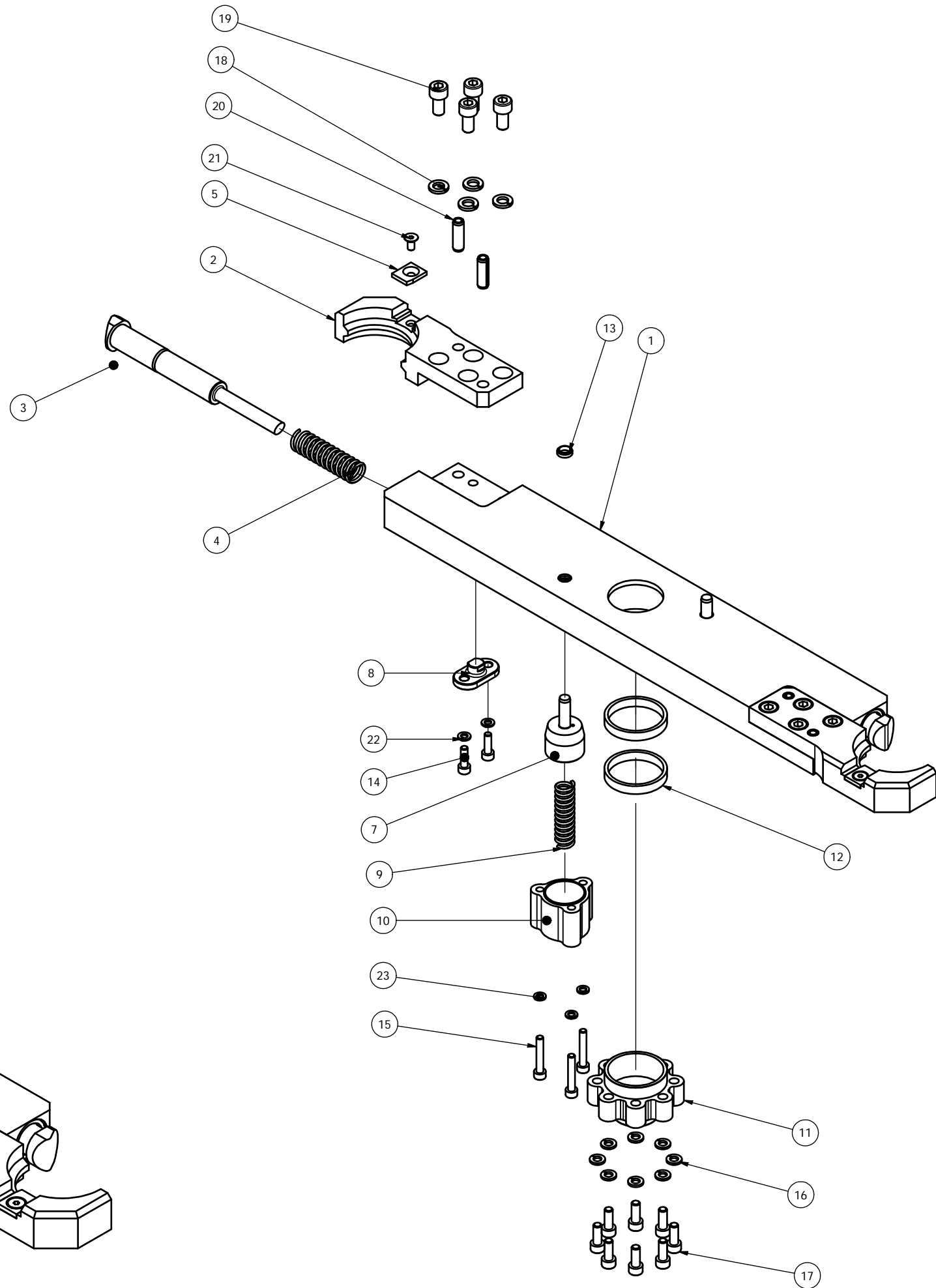

deta INTERNATIONAL  
TEL:886-4-25617722 FAX:886-4-25617177

DRAWING DESING  
NAME wayne2014/3/5

CHECK APPROVE  
PART NO. A40C-A2650111-01

UNIT NO.	QUANTITY	MATERIAL	NO.	
		TITLE	權權更新版本 2009/12/29	>0 ±0.1
		#40刀臂組(R265)		>6 ±0.2
		Arm Assembly		>30 ±0.3
				>120 ±0.5
				>350 ±0.8
				>1000±1.2

6 5 4 3 2 1

零件表

項目	零件號碼	中文名稱	英文名稱	材質	數量
1	A40C-0020A06	銅套		青銅(銅鋁合金)	1
2	OR00000P18VT	O型環 P18	O-RING P18	NBR	1
3	OT000SER18VT	刮刷環 SER18	SER18		1

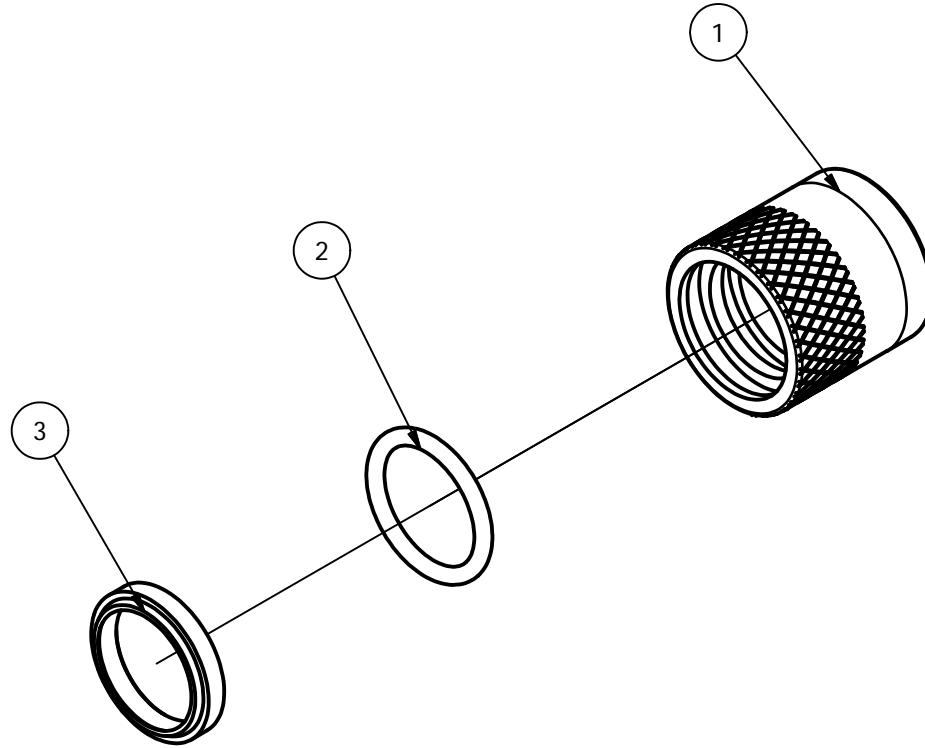

UNIT NO.	QUANTITY	MATERIAL	NO.	
			圖框更新版本	>0 ±0.1
		TITLE	2009/12/29	>6 ±0.2
PART NO.	SCALE	銅套組		>30 ±0.3
00A40C-0020C		COPPER COVER		>120 ±0.5
				>350 ±0.8
				>1000±1.2

deta INTERNATIONAL

TEL:886-4-25617722 FAX:886-4-25617177

DRAWING DESING	CHECK APPROVE
NAME	
doris2010/12/16	

6 5 4 3 2 1

## Cambox Part list

NO.	Parts No.	Specification	Q'TY	NO.	Parts No.	Specification	Q'TY	NO.	Parts No.	Specification	Q'TY
1	A01-001	Cambox	1	25	A01-023	Chain Wheel	1	49	G80	O Ring	1
2	A01-002	Box Cover	1	26	A01-024	Chain Wheel	1	50	TC30427	Oil Seal	1
3	A01-003	Cover	1	27	A01-025	Proximity Switch Holder	1	51	TB4 507212	Oil Seal	1
4	A01-004	Bearing Bracket	1	28	A01-126	Shaft Bracket	1	52	32005	Roller Bearing	1
5	A01-005	Motor Bracket	1	29	A01-027	Flange	1	53	32008	Roller Bearing	2
6	A01-006	Move Arm	1	30	A01-028	Plate Cam	1	54	30206	Roller Bearing	2
7	A01-007	Arm Shaft	1	31	A01-029	Roller Gear Cam	1	55	32011	Roller Bearing	2
8	A01-008	Arm Bracket	1	32	A01-031	Cover	1	56	6202ZZ	Ball Bearing	2
9	A01-009	Cover	1	33	A01-032	Position indicator	1	57	NTB40603	Thrust Bearing	1
10	A01-010	Bearing Bracket	2	34	A01-033	Needle Bearing	1	58	LBB5020	Bearing	1
11	A01-011	Cover	1	35	A01-133	Ring	1	59	AN05	Locking Nut	1
12	A01-012	Cover	1	36	A01-233	Washer	2	60	AN08	Locking Nut	1
13	A01-013	Cam Shaft	1	37	A01-034	Needle Bearing	1	61	AN08	Locking Nut	1
14	A01-014	Driving Gear	1	38	A01-134	Ring	1	62	AN11	Locking Nut	2
15	A01-015	Turret	1	39	A01-035	Dog Shaft	1	63	AW05	Washer	1
16	A01-016	Checking Dog	1	40	A01-036	Cover	2	64	AW08	Washer	1
17	A01-017	Braking Dog	1	41	A01-037	Needle Bearing Holder	1	65	AW11	Washer	1
18	A01-018	Idle Wheel Shaft	1	42	A01-038	Adjusting Ring	1	66	S12	Ring	1
19	A01-019	Idle Wheel	1	43	A01-040	Cover	1	67	4x8x4mm	Key	1
20	A01-020	Fork	1	44	A01-052	Rubber Seal	1	68	5x20x5mm	Key	1
21	A01-021	Spling Shaft	1	45	AS031	O Ring	1	69	10x85x8mm	Key	1
22	A01-022	Needle Bearing	6	46	AS033	O Ring	1	70	#6x38L	Taper Pins	2
23	A01-122	Ring	6	47	AS035	O Ring	2	71	1/2"10L	OIL Plug	2
24	A01-222	Washer	6	48	G75	O Ring	2	72	M12	Hook Ring	2



# Cambox

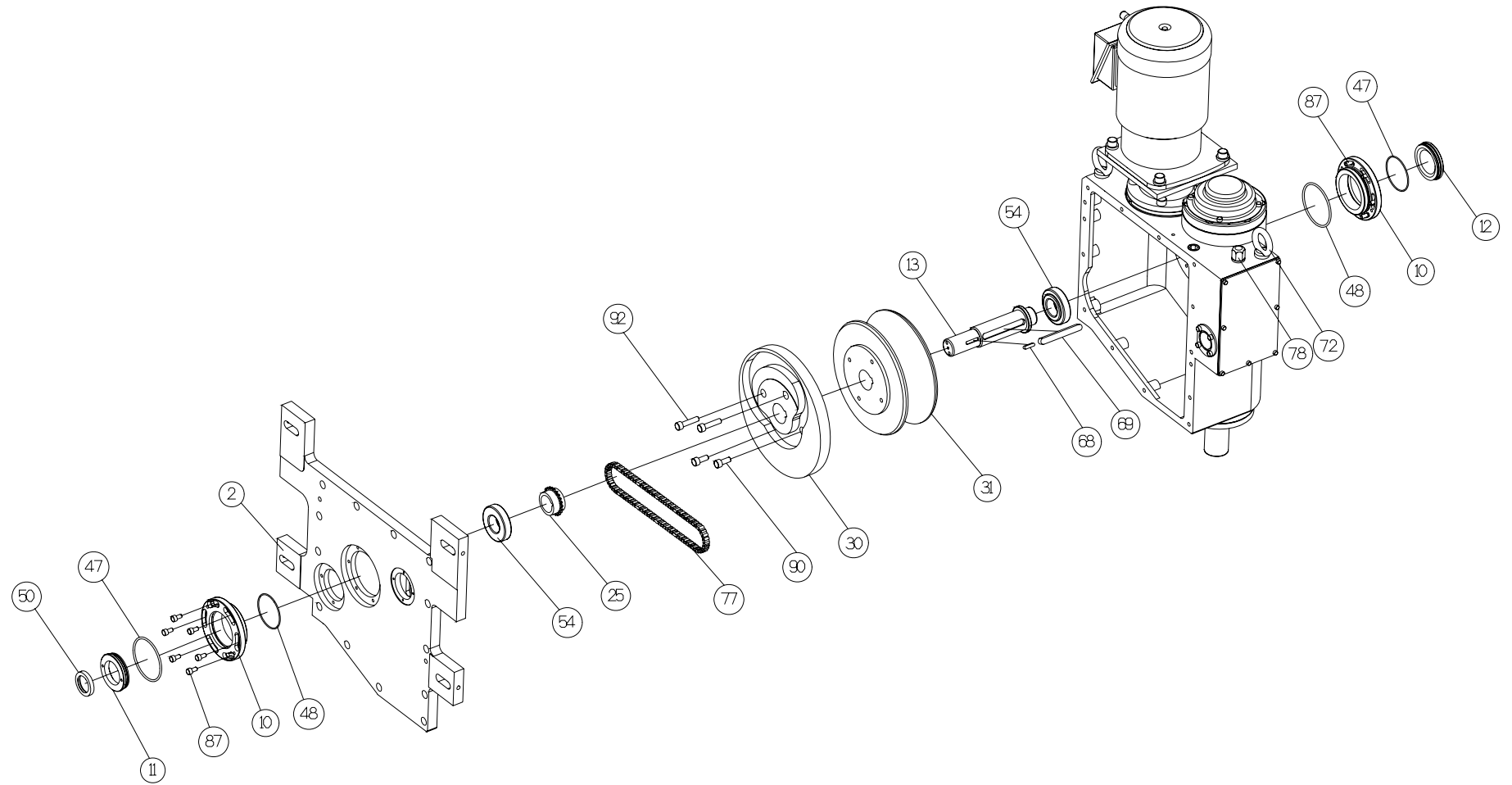

# Cambox

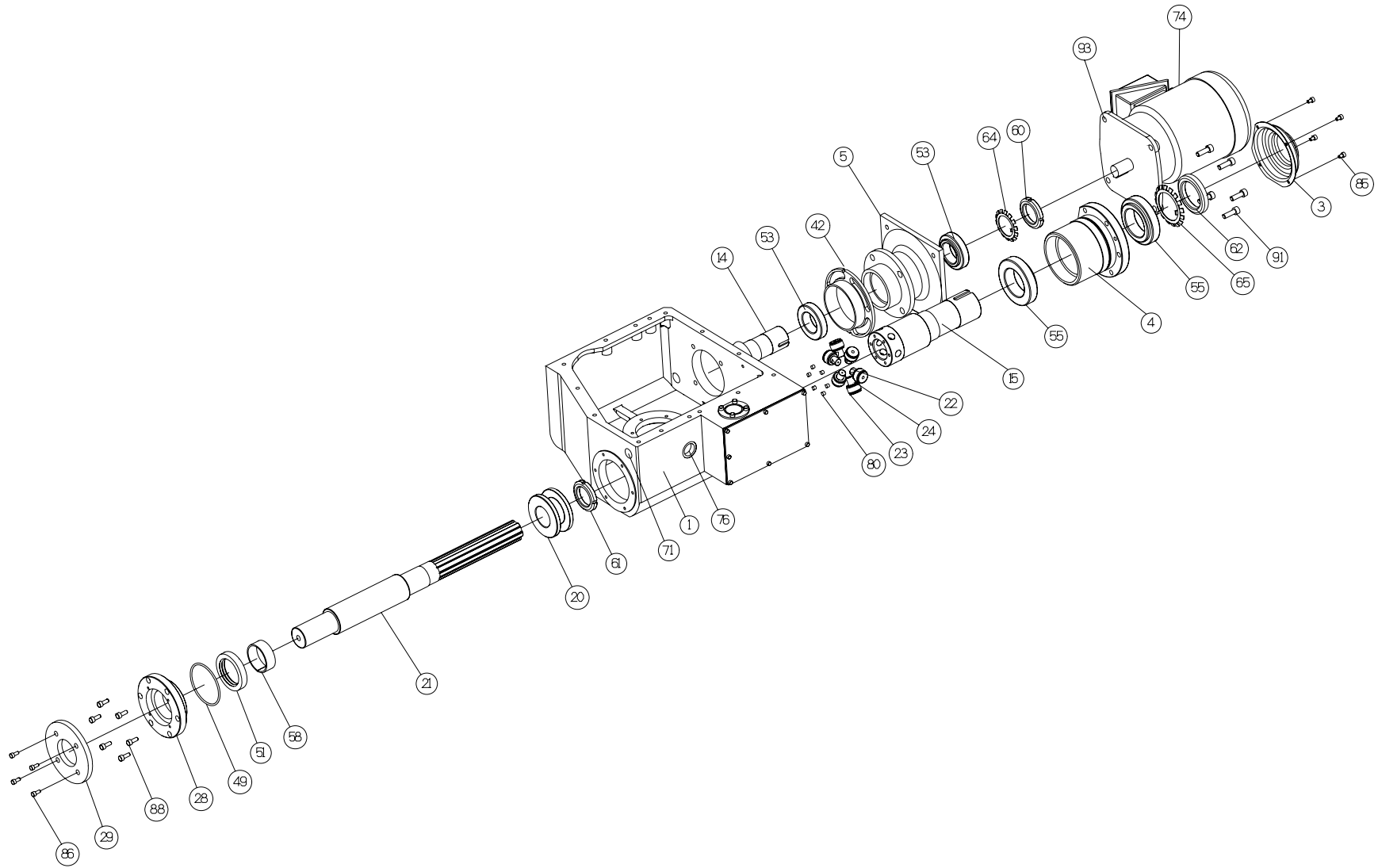

# Cambox

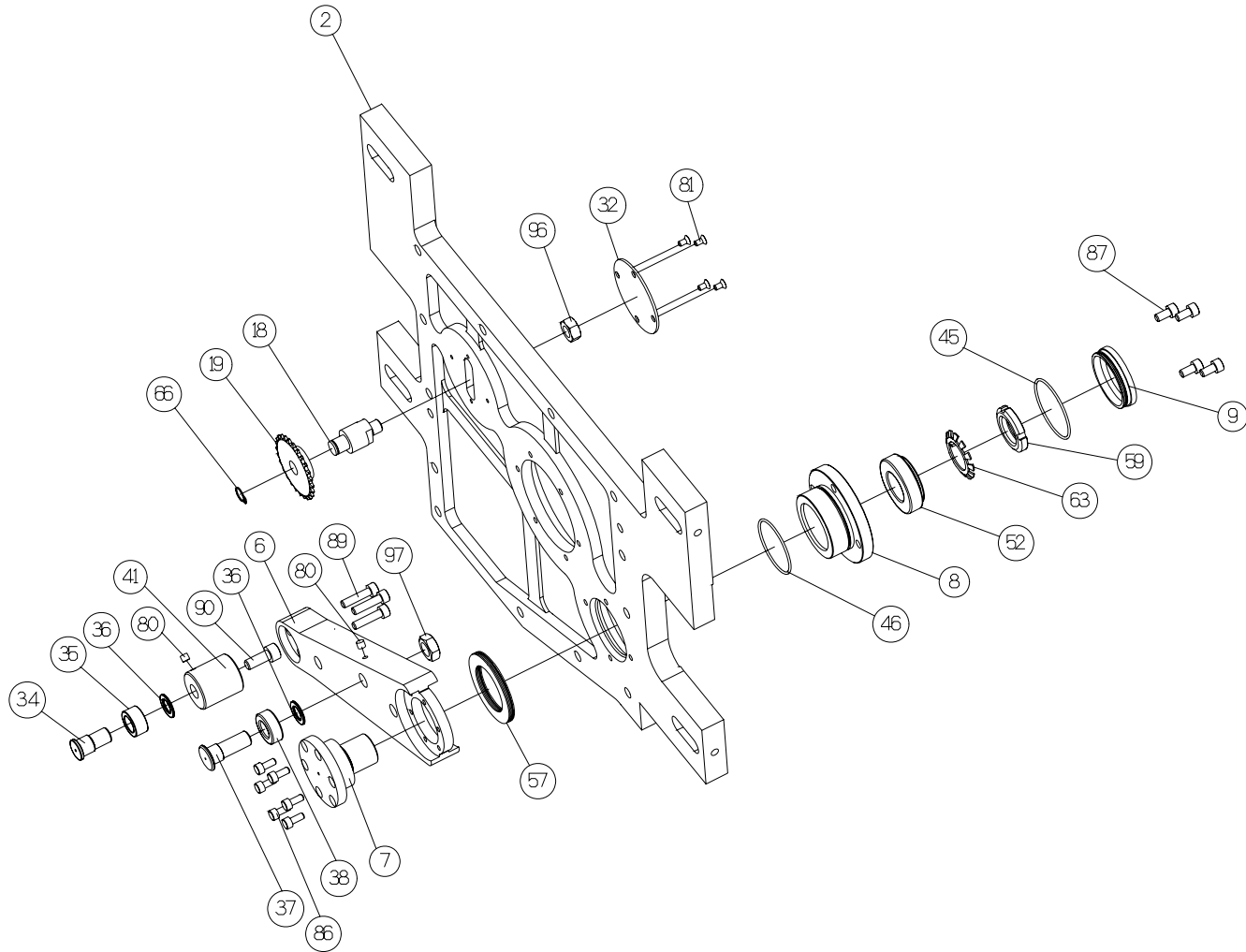

# Cambox

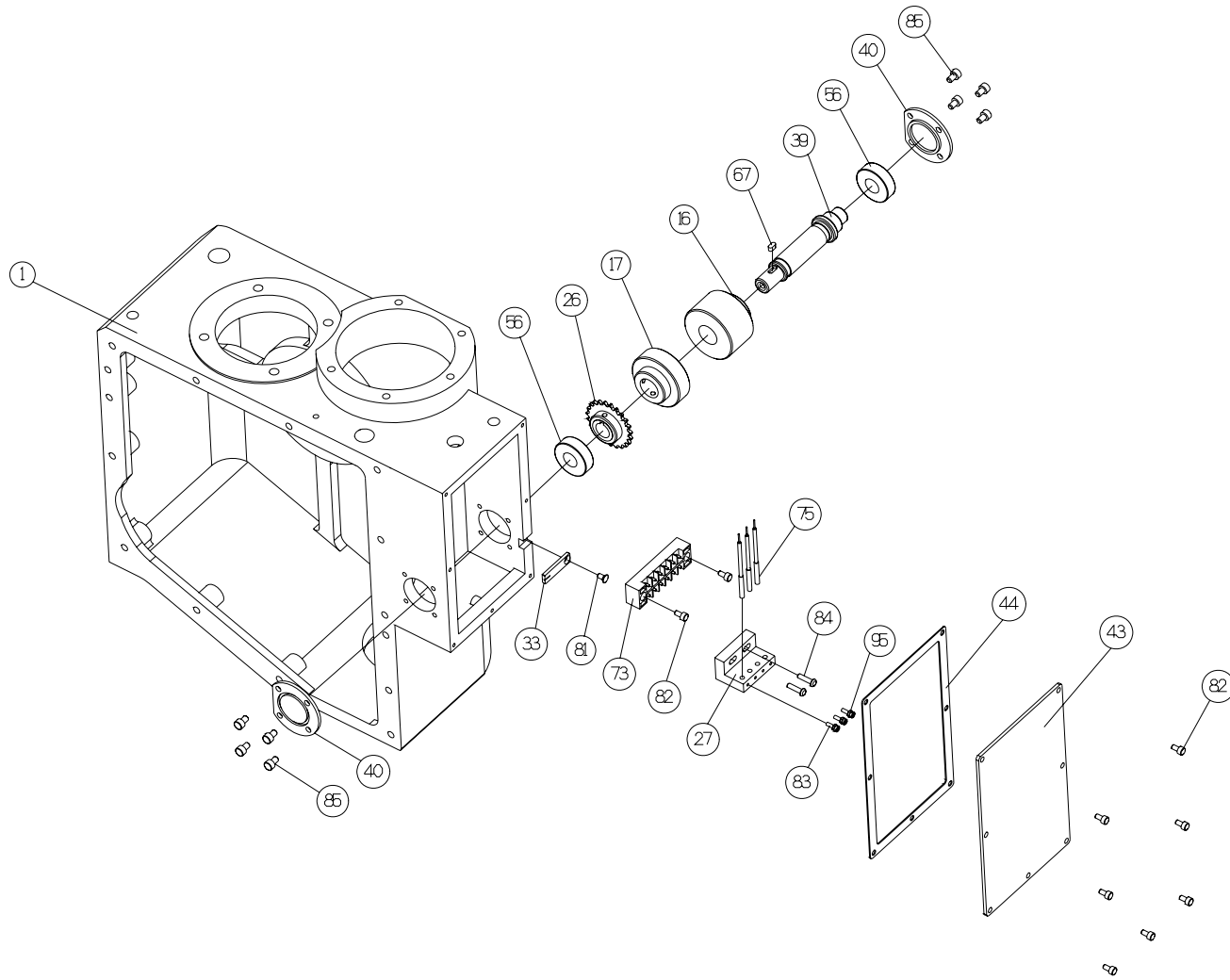



## 2 、 Power Supply Specification for Electrical Control:

### 2-1. Follow the table listed below if disk type tool-changing system's power supply is not specified:

Power Supply Category	Electrical	Pneumatic
Specification	Electrical Power Supply: 3 Phase 220V (50/60Hz) Signal Power Supply: DC 24V	5 BAR (Filtered through three- points assembly)

### 2-2. Specification of Sensor Used In disk Type Tool Changer System Are as Followed:

Sensor	Tool Magazine Positioning and Counting	Tool-Changing Mechanism
Specification	M12 PNP 24V Normal Open Shielded Distance = 0.6mm	Φ4 PNP DC24V Normal Open Shielded Distance = 0.8mm

### 3 、 Electrical Control:

Configuration Drawing for Electronic Control Components.....	DMR4L0009A01
Sequence Drawing of Tool-Changing System.....	DMR4L0010A01
Standard Wiring Diagram.....	DMR4L0011A01
Motor Wiring Diagram for Tool Magazine.....	DMR4L0012A01
Motor Wiring Diagram for CAM BOX.....	DMR4L0013A01
Pneumatic Circuit Diagram.....	DMR4L0014A01

**deta** INTERNATIONAL #40 DISK TYPE  
 TOOL-CHANGING SYSTEM SEQUENCE DRAWING

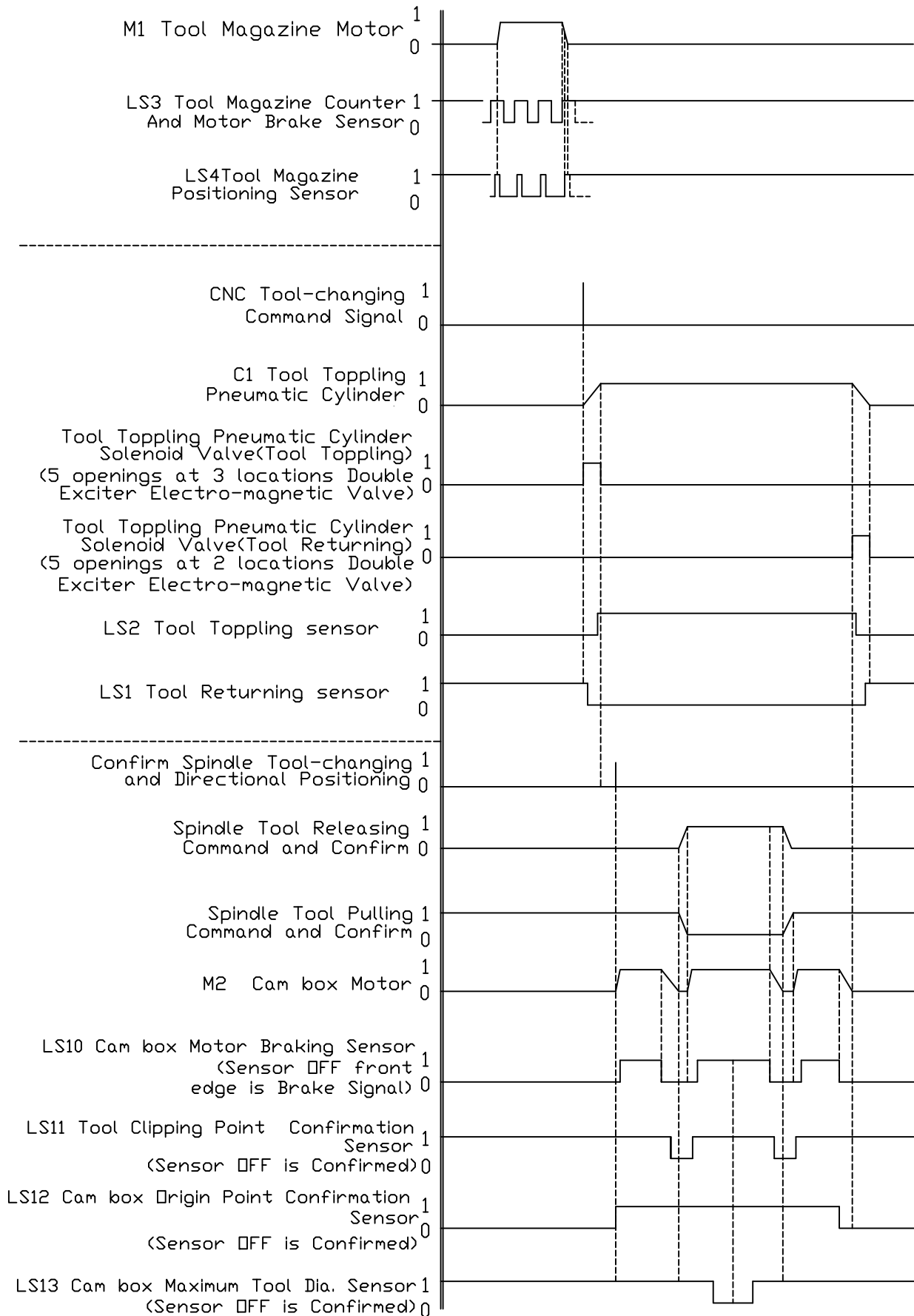

Note:1.LS3,LS4 are Type M12 PNP NO Proximity Switches used on the Tool Magazine Counter,  
 2.LS1,LS2 are Sensor  
 3.LS10,LS11,LS12 ,LS13are Type ø4 PNP NO Proximity Switches used the Cam box .(Cam box concave dog)  
 4.Tool Magazine Motor is a Three Phaes Three Cable 220V 1/2HP Motor.  
 5.Cam box Motor is a Three Phaes Three Cable 220V 1/2HP Motor.

ND:	D4-02-03 2001/12	TOLERANCE	>0 ±0.1 >6 ±0.2 >30 ±0.3 >120 ±0.5 >315 ±0.8 >1000 ±1.2
MATERIAL		QUANTITY	
TITLE		SCALE	
UNIT NO.		PART NO.	DMR4AL0010A01
CHECK APPROVE		DESIGN	Angel/2014/5/23
NAME			

#40 DISK TYPE TOOL MAGAZINE STANDARD WIRING DIAGRAM

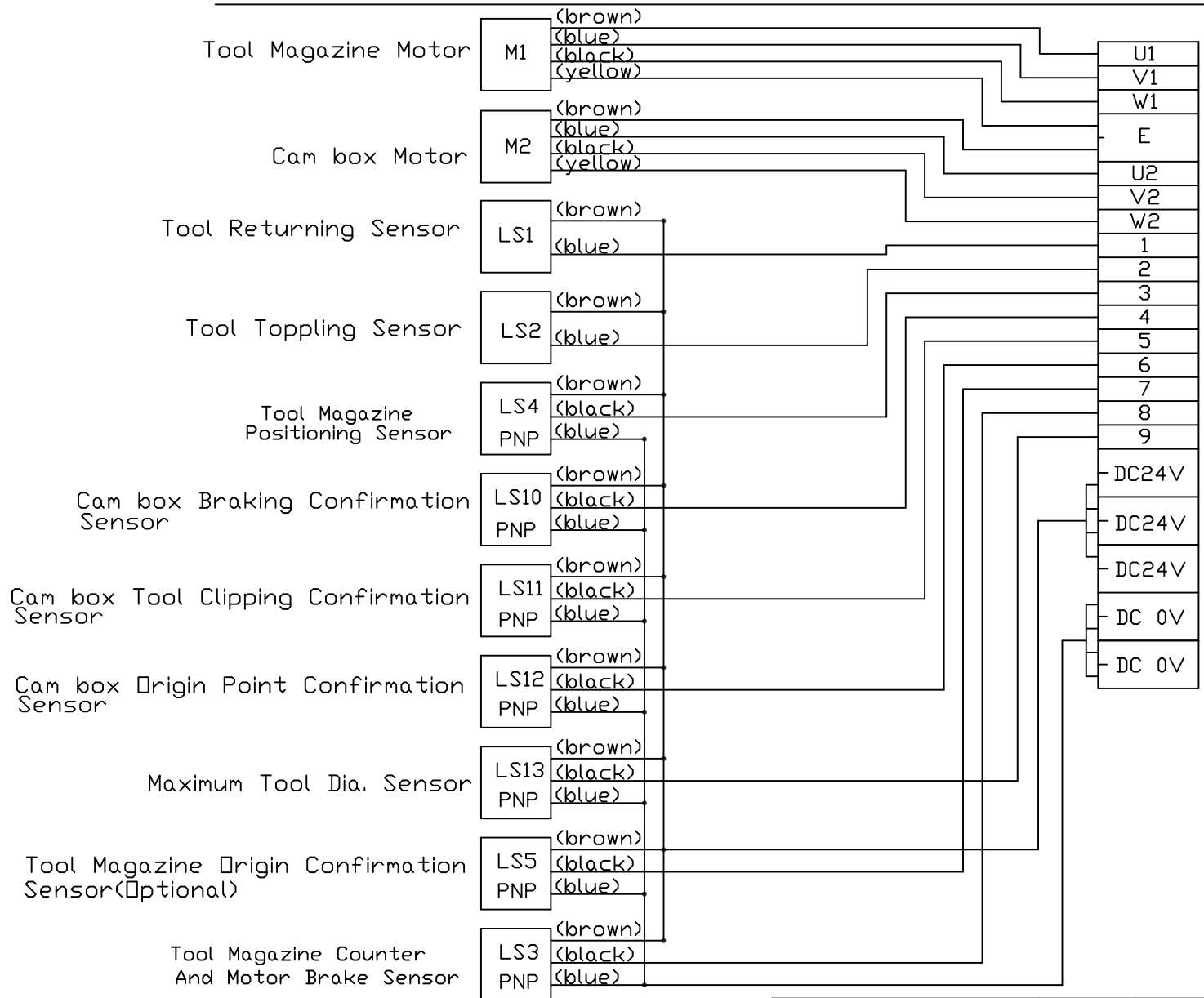

NO:	
D4-02-03	TOLERANCE
2001/12	>0 ±0.1
	>6 ±0.2
	>30 ±0.3
	>120 ±0.5
	>315 ±0.8
	>1000 ±1.2

UNIT NO.	QUANTITY	MATERIAL
PART NO.	SCALE	TITLE
DMR4AL0011A01		

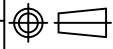

# deta INTERNATIONAL #40 DISK TYPE TOOL MAGAZINE MOTOR WIRING DIAGRAM

Tool Magazine Motor external view

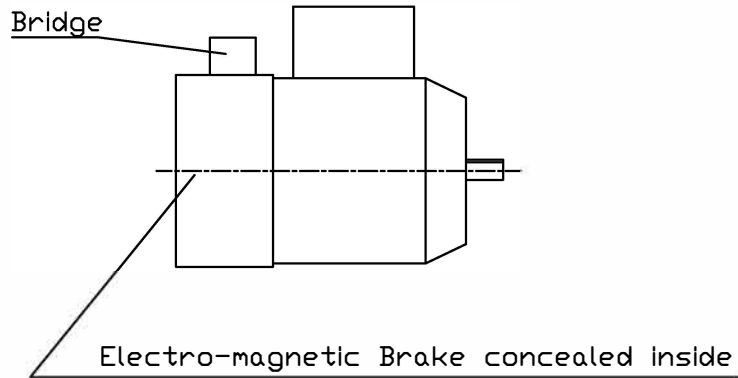

**Tool Magazine Motor Electrical Specification:**

1.Horse Power:	1/4HP	6.Insulation Resistance:	100M?
2.No. of Poles:	4P	7.No Load Current:	1.0A
3.voltage:	60HZ,220V	8:Full Load Current:	1.9A
4.Rotational Speed:	1720R.P.M.	9:Brake Gap:	0.2~0.35mm
5.Hi Pot:	1800V.A.C		

A.The tool magazine motor is a 1/4HP three phase induction motor with electro-magnetic brake (Power Off Braking).

wiring diagram as follow

AC 220V 3 phaes

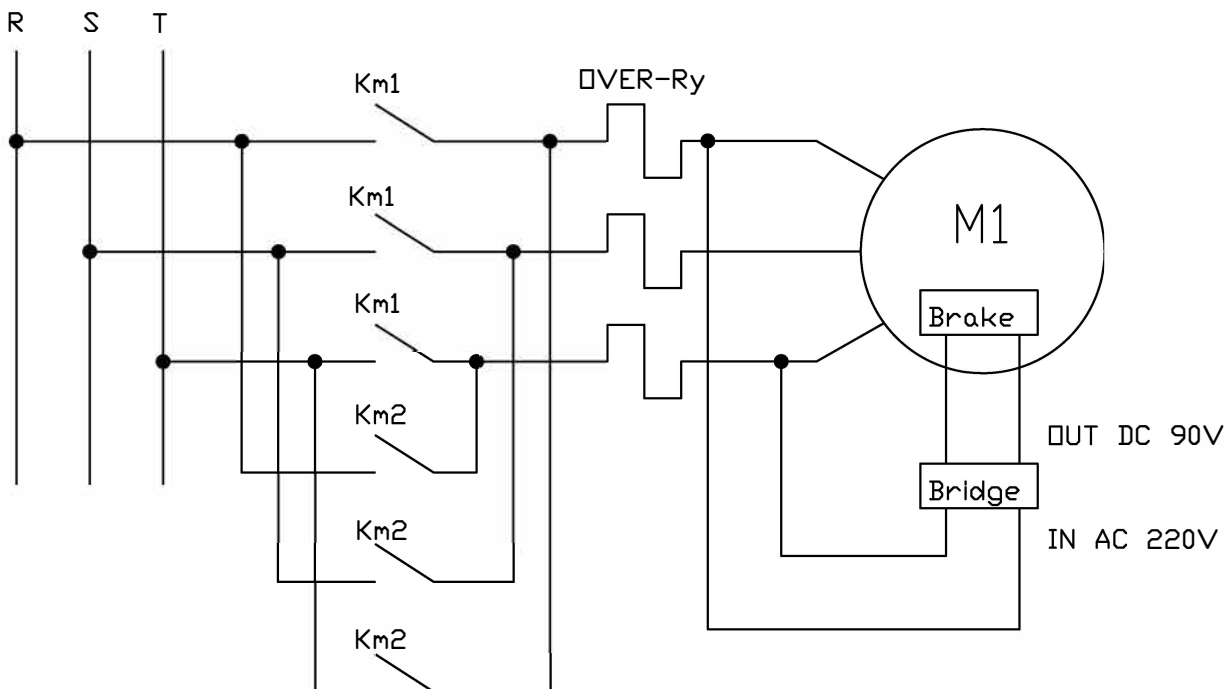

NDI:	D4-02-03 2001/12	TOLERANCE	>0 >0.1 >0.2 >0.3 >0.5 >1.20 >315 >1000
QUANTITY	MATERIAL	TITLE	SCALE
UNIT NO.	PART NO.	DMR4AL0012A01	
DRAWING DESIGN		CHECK APPROVE	
NAME ANGEL2014/5/23			

# deta INTERNATIONAL #40 DISK TYPE CAM BOX MOTOR WIRING DIAGRAM

## MOTOR EXTERNAL VIEW

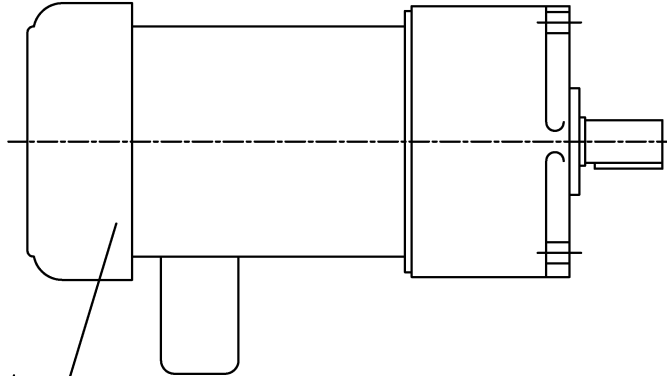

Electro-magnetic Brake concealed inside

### Cam box Motor Electrical Specification:

- |                     |            |                          |               |
|---------------------|------------|--------------------------|---------------|
| 1.Horse Power:      | 3/4HP      | 6.Insulation Resistance: | 100M $\Omega$ |
| 2.No. of Poles:     | 4P         | 7.No Load Current:       | 1.15A         |
| 3.voltage:          | 60HZ,220V  | 8.Full Load Current:     | 2.0A          |
| 4.Rotational Speed: | 1720R.P.M. | 9.Brake Gap:             | 0.3~0.35mm    |
| 5.Hi Pot:           | 1800V.A.C  |                          |               |

Note: Electro-magnetic Brake Voltage and Motor Voltage are the equal.

WIRING DIAGRAM AS FOLLOW  
AC 220V 3 PHAES

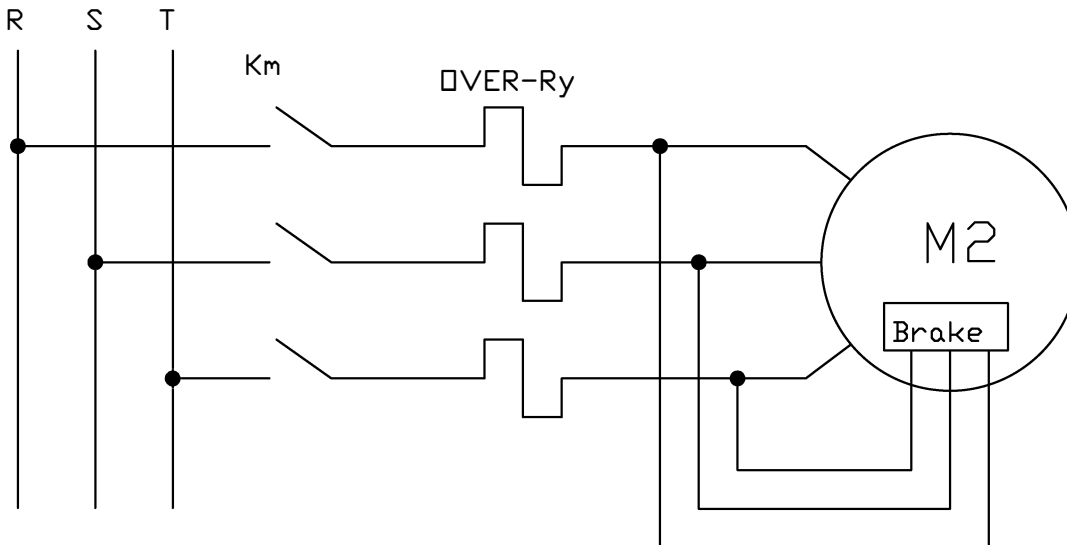

ND:	D4-02-03 2001/12	TOLERANCE	>0 ±0.1 ±0.2 ±0.3 ±0.5 ±0.8 ±1.2
UNIT NO.		QUANTITY	
PART NO.	DMR4AL0013A01	SCALE	TITLE
CHECK	APPROVE	DRAWING DESIGN	NAME
		ANGEL / 2014/5/23	ANGEL
TEL: 886-4-25617722 FAX: 886-4-25617177			



## 4 、 Electrical Control Protection Programming:

- (1) As Cam box and the tool magazine move extremely fast, the control program for all motor relays, sensors, and the I/O port of electromagnetic valves should be written on PLC Level 1 of the controller (where SCAN TIME reacts faster). This is to prevent the electronic control from having over slow reactions and causing the machine to make wrong movements.
- (2) In the proceeding of tool changing, each movement has to be confirmed for its completion before continuing with the next movement. (Refer to the tool-changing flowchart diagram)
- (3) Do not topple the tool if the sensor for the positioning of the tool magazine is not confirmed (i.e. LS4 is ON).
- (4) Do not start the motor of the tool magazine or rotate the tool palette if LS2 is OFF in the proceeding of tool tilt and LS1 is ON before confirming the completion of tool tilt.
- (5) Do not change the tool if tool tilt is not confirmed (i.e. LS1 is ON).
- (6) Do not change the tool if the spindle of the machine has not returned to the tool changing position.
- (7) Do not change the tool if the spindle orientation has not been completed.
- (8) Do not move the spindle head if the arm has not return to its home position.
- (9) Overload protection relay should be activated when overloading, so that the motor will not be burn off.
- (10) The amperage of the motor's current has to be below the motor's full load current.  
1/4 Hp: 1.2 A; 1/2 Hp: 2 A; 3/4Hp:2.8 A;1 Hp: 3 A (at 60Hz)



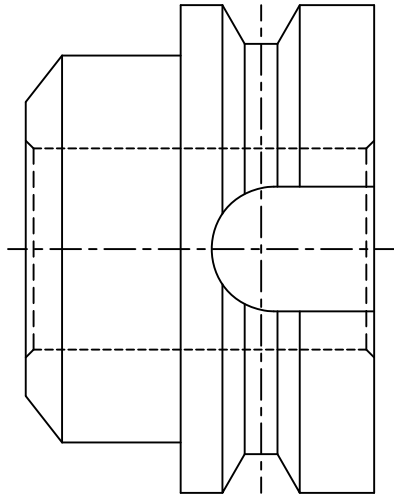

FIXTURE B

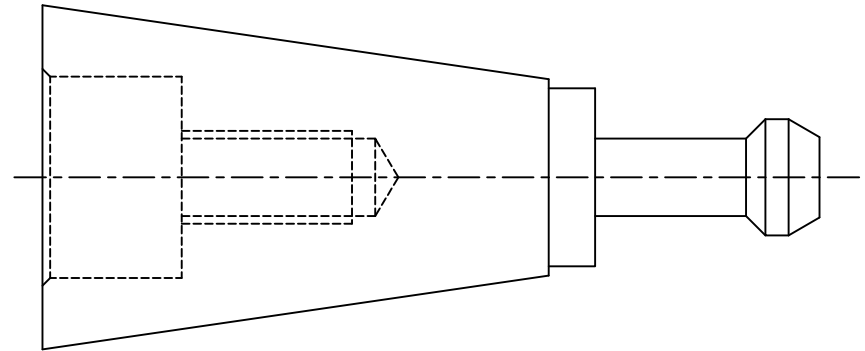

FIXTURE A

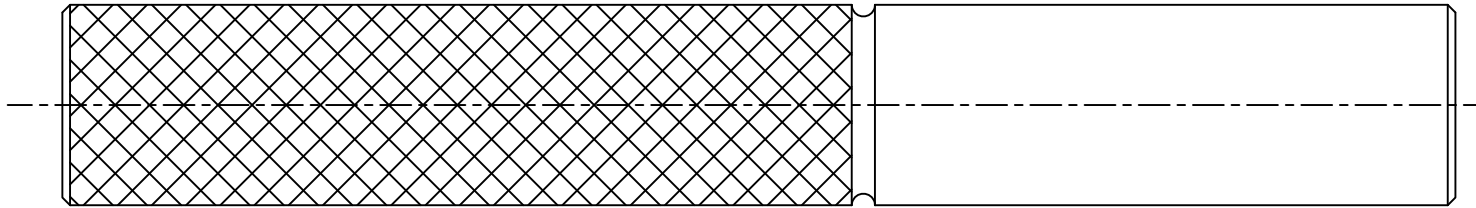

FIXTURE C

NO:	
D4-02-03 2001/12	TOLERANCE
	>0 ±0.1
	>6 ±0.2
	>30 ±0.3
	>120 ±0.5
	>315 ±0.8
	>1000 ±1.2

UNIT NO.	QUANTITY	MATERIAL
PART NO.	SCALE	TITLE
DMR4AL0017A01		

DRAWING DESIGN	CHECK APPROVE
NAME A-MAY2004/1/15	

**deta** International

TEL:886-4-25617722 FAX:886-4-25617177

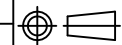

## 5 、 Installation Procedure:

Before installing our disk type tool-changing system, you should read this section carefully and understand it completely before proceeding with the installation procedure.

Adjustment of the arm and the tool magazine was done before the product left our factory, users do not have to spend time to work on it. Hence, users could treat the tool magazine, the tool-changing mechanism and the tool arm as a complete unit without having to do any adjustment when installing our Disk Type Tool Changing System. But the tool-changing point of the spindle and the tool-changing point of the arm have to be accurately adjusted.

The tool-changing point of the spindle and the tool-changing point of the arm have to be accurately overlapped, so that tool-changing movements will be smoothly carried out under normal usage without any collision noise. If the adjustment is inaccurate, not only tool-changing movements will not be smooth but it will also produce collision noises, which will have harmful effect on the life span of the tool. Hence, the only important point for installing our Disk Type Tool Changing System is “to overlap the tool-changing point of the spindle and the tool-changing point of the arm accurately”. We recommend users to follow the installation procedures below:

- (1) Make an interfacing bracket as we have suggested, and lock it onto the vertical column after confirming the bilateral perpendicularity geometrical tolerance between the vertical column interface and the tool magazine interface.
- (2) Make a three-stages tool-calibration fixture as we have suggested. (As per attached drawing)
- (3) Lock the disk type tool-changing system onto the interfacing bracket. Put the two rest blocks closely on the top of the interfacing bracket and ensure the horizontal accuracy is kept.
- (4) Move the Z-direction of the spindle to the highest point.
- (5) Put adjustment fixture A into the spindle for the spindle to grip and let the tool-changing arm grip adjustment fixture B. Press and release the brake, which is on top of the tool-changing mechanism motor. Then use a hexagonal spanner to turn the screw, which is

located at the top center of the motor, until the tool-changing mechanism reaches the tool-clipping position. (Keep turning the screw on top of the tool-changing mechanism motor, and the tool-changing arm will remain fixed for a period of time. This will ensure that the tool-clipping position has been reached).

- (6) Use a level to adjust the interfacing bracket so that the tool-changing arm is perpendicular to the spindle.
- (7) Move the Z-direction of the spindle to about 2mm from the top of the predicted tool-changing point.
- (8) Adjust the X- and Y-direction of the tool-changing system so that the X- and Y-coordinate of the tool-changing points for the tool-changing arm and the spindle overlap. If adjusting the Fixture C allow it to pass through the Fixture B and entering the internal hole of the Fixture A that means the X and Y direction adjustment is completed.
- (9) Measure the Z-direction coordinate for the tool-changing point of the down to approximately 0.3~0.5mm above the Z-direction coordinate of the tool-changing point for the tool-changing arm (the ideal distance would be 1/2 of the spindle clamp distance). And set this point as the coordinate for the tool-changing point. Again, use the hexagonal spanner to turn the screw on the top center of the motor in the opposite direction, until the tool-changing mechanism returns to its home position.
- (10) Change the tool manually first, to check that the movements of tool pot toppling, the tool-changing mechanism performing the tool-change, the spindle catching and releasing tools, ... etc coordinate well together without any error, then proceed with CNC automatic sequence program control. After trial tool-changing several times and making sure that no bad phenomena appear, the positioning pins can be fix into positions between the tool-changing system and the interfacing bracket, and between the interfacing bracket and the vertical column, respectively.
- (11) Connect the circuit for electronic control, pneumatic valves, and pneumatic source according to the wiring diagram.
- (12) Pour the hi-grade of circulation oil into the tool-changing mechanism until the surface of the oil can be seen from the oil-viewing window

## 6 、 Original Setting:

- (1) The gap between the tool magazine orientation and the counter sensor (M12) and the sensor block should be adjusted to between 0.8~1.0 mm.
- (2) The gap of tool magazine motor's brake pad should be adjusted to between 0.2~0.35 mm.
- (3) The gap between the sensor ( $\Phi 4$ ) on Cam box tool-changing mechanism and the sensing block should be adjusted to between 0.4~0.5 mm.
- (4) The gap of Cam box motor's brake pad should be adjusted to between 0.3~0.35 mm.

## 7 、 Troubleshooting:

### 7-1. Unstable tool tilting:

We have made the best adjustment to the disk type tool-changing system before our product left our factory, and we would suggest users not to do any random adjustment. If tool tilt is unstable due to the transportation or human error, please follow the procedures below to check and make adjustment:

- (1) Check whether the pneumatic source conform to the power supplying specification (refer to the section on the electrical control's power supply specification).
- (2) Check whether the tool tilting mechanism has any damage to it. If so, please contact us and we will send someone over to repair it.

**※Note: Be sure not to set the speed too fast, otherwise there is a possible danger of dropping the tool.**

## 7-2. Tool Calibration Procedure

Please adjust the arm as following procedure when need:

- (1) Use an overhead crane to lift the Cam box and inspect it externally for any flaw.
- (2) Use M12×50L + spring washer + flat washer to fasten the Cam box onto the datum surface of the tool magazine's main structure, and pull the Cam box to the elongated holes on the outside.
- (3) Open the power distribution box of the Cam box and connect it to the power supply of the electronic control box. Check to see if there is any abnormal phenomenon in the operation of the Cam box.
- (4) Tighten the nut and sun washer on the Cam box shaft ° (as illustrated in Diagram 1).

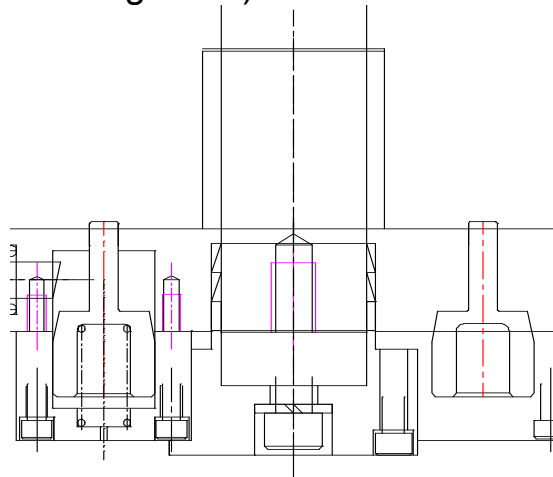

- (5) Use M5×35L bolt + spring washer to fasten the packing rings on the tool-changing arm, but do not tighten it temporarily.
- (6) Sequentially insert the separation ring for the tool-changing arm and put the tool-changing arm into the Cam box axis, and fasten M12×35L bolt + spring washer onto the tool-changing arm with a bit tightness around the axis and without any gaps.
- (7) Supply electrical power to Cam box to allow the Cam box axis to rotate to the tool-clipping angle.
- (8) Use the three-point tool calibration fixtures to adjust the position of the tool-changing arm. The adjustment method is to insert Fixture

A into the tool pot, and Fixture B is placed at the tool clipper and coupled with the protuberance, but the tool pusher clip has to be placed into the arm first. Then, re-adjust the Cam box position, so that Fixture C can go through Fixture A and Fixture B and reach the arm at the position of the tool-clipping point, and line up with the center of the tool pot.

- (9) Tighten the Cam box on the magazine with 4.M12X12L screws ◦
- (10) Check the clearance between the flange of the clip and tool flange ,if the toper cleanses is equal to lower cleame are the same ◦ (the cleame is 0.8mm for BT and that is 0.2mm for CAT and DIN Tool shank)if the toper cleame is not equal to lower clew , one nut move the above set of Cam box and arm up or down ◦ (as illustrated in Diagram 2).

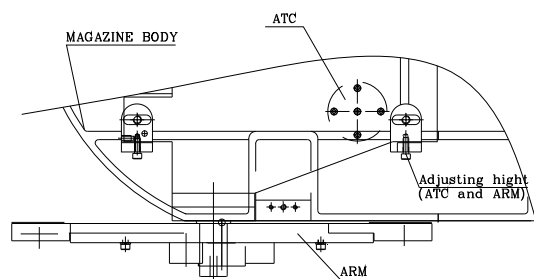

- (11) In the process of tightening, use magnetic holder to hold the leveler on the Cam box. The pointer of the leveler should touch the tool clipper near the outer rim. Repeat the height measurement for both ends of the tool clipper, where the height at both ends should be within 0.1mm of difference.
- (12) Place the tool pusher clip spring onto the end of the tool pusher clip, and after smearing some lubricating oil, fit it into the tool-changing arm. Fix M8 anti-revolving bolt + spring washer to the arm (as illustrated in Diagram 3).

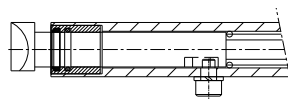

- (13) Turn the manual bolt behind the Cam box motor, so that the tool-changing arm descends about 50mm. Apply lubricant on the safety pusher pin of the tool-changing arm and then insert it into the lubricated spring of safety pusher pin. Then, insert the safety pusher pin into the tool-changing arm and fasten it with M5×35L bolt + spring washer (as illustrated in Diagram 1).
- (14) After fastening the parts for the tool-changing arm, try several times to make sure that the safety pusher pin can spring upwards freely, and test to see if tool-changing movement is working properly by putting a tool into the tool pot.

### **7-3. When the tool palette not turning smoothly:**

- (1) Please check to see if there is any foreign object got stuck to the Geneva wheel or drive shaft (refer to the assembly drawing and part list). Please eliminate it.
- (2) Please dismantle the motor and then electrify the motor, so it operates independently. Check to see if it rotates smoothly without any noise.
- (3) If after going through above inspections without eliminating the breakdown, please contact our company.

### **7-4. When the tool arm motion not smooth:**

- (1) Please check to see if there is any damage to the tool-changing arm. If there is, please contact our company to have the parts replaced.
- (2) Please check the tool-changing mechanism and main structure of the tool magazine to see if there is any change to the locking position (Check to see whether there is any damage to the positioning pin or it has already been shear off. If there is, please contact our company to have the parts replaced.
- (3) Please check whether there is any loose movement between the tool-changing arm and axis of the tool-changing mechanism. If there is, please stop the machine and cut off the power supply and loosen the screw on top center of the motor with a hexagonal spanner until the tool-changing mechanism reach the tool clipping position. Push the tool-changing arm upward to the end and clip on the tool that has toppled down, then calibrate both end of the tool-changing arm so they are within (0.1mm) in height, (Refer to tool calibration procedure)
- (4) Be sure not to self dismantle the tool-changing mechanism, if there is any breakdown, please contact our company.

### **7-5 When the tool-changing speed is too slow:**

- (1) Please check whether the motor produces any strange noise
- (2) Please check whether the power supply conform to the specification.



(3) Please check whether the speed of spindle clamping and unclamping complies with the requirement.

(4) There is any other breakdown, please contact us.

### **7-6. Sudden power failure during the course of tool change by the tool-changing arm**

- (1) For short period of power failure, please re-start the machine, and manually return the tool-changing arm to its original position.
- (2) For long period of power failure, please release the motor brake, rotating the tool-changing arm to its original point location by using a spanner to turn the spindle on top of the Cam box motor, and ensure the safety of the machinery by forcing the tool pot to return the tool.

## **8 、 Maintenance:**

- (1) The circulation oil inside the tool-changing mechanism should be changed after 2400 hours of continuous usage. And the oil level has to be checked non-periodically. A refill is in order if the oil falls below the required level.
- (2) Tool disk and cylinder mounting plate's surface need to be greased every month.
- (3) Check and see if there is still some lubricating oil in the bearing every three months.

Thank you for using our products. Please inform us if there is any defect so that we can make improvements and offer you more stable and better quality products.

**deta** *International*

**Address: No. 287, Kang Zhuang Road, Zhou Shi Town, Kun Shan City, Jiangsu Province**

**Tel: 0512-57664275**

**Fax: 0512-36822333/36822555**

**Sales department e-mail      [sales@deta-china.com.cn](mailto:sales@deta-china.com.cn)**

**Design department e-mail      [sales@deta-china.com.cn](mailto:sales@deta-china.com.cn)**

---

---

**Address: No. 47-5, Zhen Qian Road, Shen Kan Village, Taichung, Taiwan**

**Tel: (886-4) 2561-7722**

**Fax: (886-4) 2561-7177**

**Sales department e-mail      [sales@deta.com.tw](mailto:sales@deta.com.tw)**

**Design department e-mail      [design@deta.com.tw](mailto:design@deta.com.tw)**